

Dial Type Air Gage

MD SERIES Instruction Manual



NIDEC-SHIMPO CORPORATION

DIAL TYPE AIR GATE

MODEL MD SERIES

INSTRUCTION MANUAL

NIDEC TOSOK CORPORATION

CONTENTS

| | Page |
|--|------|
| 1. General | 1 |
| 2. Model No. and Type | 2 |
| 3. Specifications | 4 |
| 4. Principles of Operation | 5 |
| 5. Preparation | 6 |
| 6. Adjustment | 7 |
| 7. Maintenance and Operating Precautions | 10 |
| 8. Troubleshooting | 11 |
| 9. Special applications | 12 |

1. General

TOHSOKU Dial Type Air Gage Model MD Series is a precision comparator utilizing highly pressurized air, and is designed to indicate a change in the back-pressure which occurs corresponding to the micro-displacement of workpiece. The measurements are given on the dial indicator.

The measuring range can be varied by changing the dial plates. In addition, the MD Series has various advantages due to the use of high control pressure of 3 kg/cm².

M and H types use a specially designed amplifier relay, enabling to increase the magnification.

MD Series consists of two models :

Model MD-14 : Indicates single dimension with one pointer.

Model MD-24 : Indicates two dimensions at a time with two pointers.

2. Model No. and Type



Model MD-14

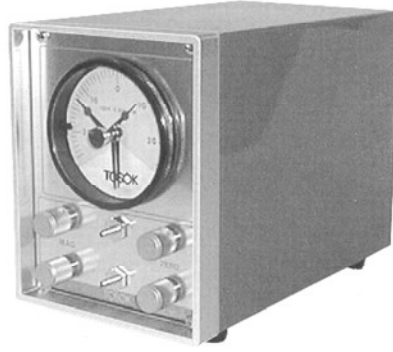

Model MD-24

2-1 System of Model No. is as follows :

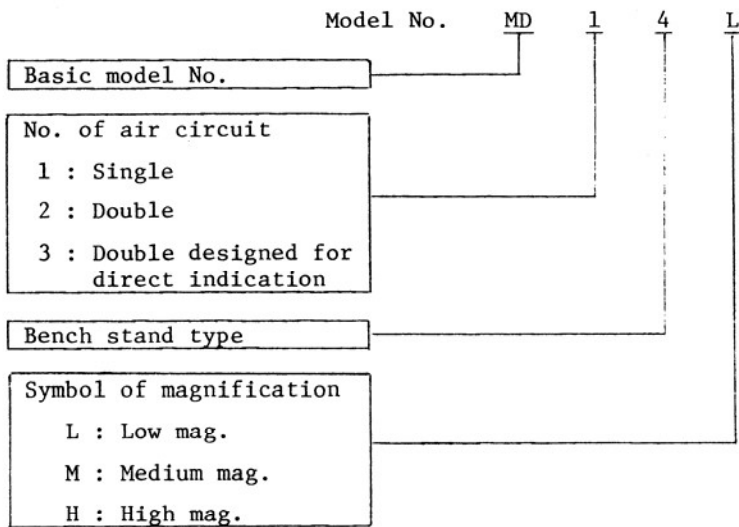

2-2 MD Series

MD-14 series : One-point measurement

MD-24 series : Two-point measurement

| | | |
|--------|-------------|-------------|
| MD-14L | Low mag. | Single type |
| MD-14M | Medium mag. | |
| MD-14H | High mag. | |
| MD-24L | Low mag. | Double type |
| MD-24M | Medium mag. | |
| MD-24H | High mag. | |

MD-34 Series

Makes measurements at two points simultaneously and indicates the respective measured values. Also, makes addition and subtraction of the measured values and indicates the result on another indicator.

| | | |
|-------------------------------------|-------------|------------------|
| MD-34SL ⁻² ₋₃ | Low mag. | Subtraction type |
| MD-34AL ⁻² ₋₃ | | Addition type |
| MD-34SM ⁻² ₋₃ | Medium mag. | Subtraction type |
| MD-34AM ⁻² ₋₃ | | Addition type |
| MD-34SH ⁻² ₋₃ | High mag. | Subtraciton type |
| MD-34AH ⁻² ₋₃ | | Addition type |

MD-34□□-□

- 2 : Vertical type cabinet
 3 : Horizontal type cabinet

2-3 Dimensions and Weight

| Model | Dimension of cabinet (mm) | Weight (kg) |
|------------------|---------------------------|-------------|
| MD-14L | 190 x 152 x 177 | 5.4 |
| MD-14M MD-14H | 190 x 152 x 264 | 7.5 |
| MD-24L | 190 x 152 x 264 | 6.9 |
| MD-24M MD-24H | 190 x 152 x 264 | 8.0 |

3. Specifications

3-1 Scale plate

The scale plate can be easily changed according to measuring conditions.

The following scale plates are available :

| Model No. | Range of scale plate | Full scale (μm) | Graduation (μm) |
|-----------|----------------------|------------------------------|------------------------------|
| MD-14L | 100 - 0 - 100 | 200 | 5 |
| | 50 - 0 - 50 | 100 | 2 |
| MD-24L | 25 - 0 - 25 | 50 | 1 |
| MD-14M | 10 - 0 - 10 | 20 | 0.5 |
| MD-24M | | | |
| MD-14H | 5 - 0 - 5 | 10 | 0.2 |
| MD-24H | | | |

Note : 1) Dia. of scale plate : 90mm

2) Zero center type : Full scale is 240°

3) Unless otherwise specified, scale plates shown in thick enclosure on the above table are supplied as standard items.

4) Special scale plates are also available upon request.

3-2 Performances

| Full scale (μm) | Graduation (μm) | Magnification | Effective indication range | Accuracy of effective indication range | | Max. measuring clearance | Response time (sec) |
|------------------------------|------------------------------|---------------|----------------------------|--|---------------|--------------------------|---------------------|
| | | | | Indication tolerance | Repeatability | | |
| 200 | 5 | 880 | 150 | 2.5 or less | 1.5 or less | 250 or more | 0.5 or less |
| 100 | 2 | 1,800 | 72 | 1.0 | 0.6 | 200 | 0.5 |
| 50 | 1 | 3,500 | 36 | 0.5 | 0.3 | 150 | 0.5 |
| 20 | 0.5 | 8,800 | 14 | 0.3 | 0.2 | 60 | 0.8 |
| 10 | 0.2 | 18,000 | 6 | 0.1 | 0.1 | 40 | 0.8 |

Note : 1) The values shown in the above table are those attainable under room temperature of 20°C using a standard stand.

2) Use of regulator together with high magnification type (MD-14H, MD-24H) is recommendable.

3-3 Air source

$4 \text{ kg/cm}^2 \sim 8 \text{ kg/cm}^2$

4. Principles of Operation

The filtered air supplied from the air source in the factory is accurately adjusted by the regulator. The constantly pressurized air is sent to the nozzle of the gaging head through the magnification adjust throttle, and it is also supplied to the booster relay (for L type Air Gage), and to the amplifier relay (for M type and H type Air Gages).

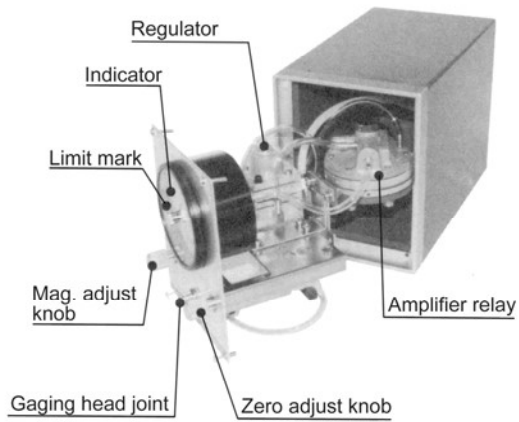

The air is discharged into the atmosphere from the nozzle of the gaging head and the zero adjust throttle. (MD-24 Series have two independent circuits as shown in Fig. 1.)

The pressure (back pressure) between the zero adjust throttle and the nozzle of the gaging head changes according as the clearance between the workpiece measured and the nozzle of the gaging head changes. As a result, the back pressure is applied to the indicator so that the pointers (black and red for MD-24 Series) indicate measured values respectively.

(M type and H type Air Gages are so designed that the back pressure is supplied as an input to the amplifier relay and then the output of the amplifier relay is applied to the indicator.)

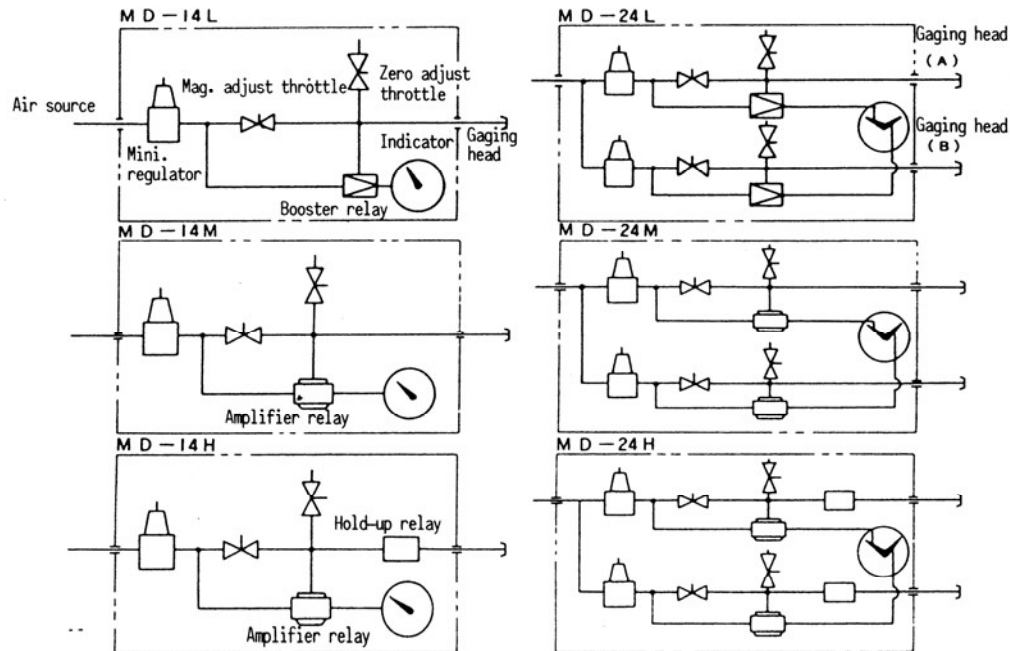

5. Preparation

- 5-1 Install the supplied filter unit at a lower position near the main unit as much as practicable and also fix it vertically to an easy-to-drain position.
Connect the hose nipple of the filter unit to the air source in the factory.
When using a dehumidifier, connect the air source in the factory and the filter unit with a hose.
- 5-2 Connect the filter unit with the supply nipple on the rear of the main unit as shown in the Fig. below :

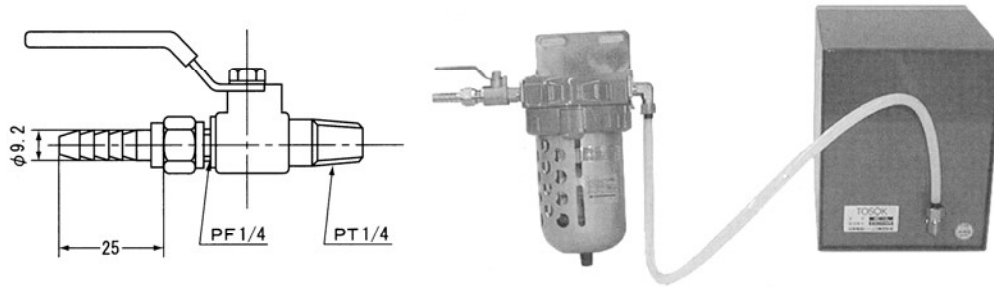

- 5-3 Connect the main unit with the measuring unit and securely tighten the connection.
Check that no air is leaking.
- 5-4 When the above preparation is completed, open the cock of the filter unit.

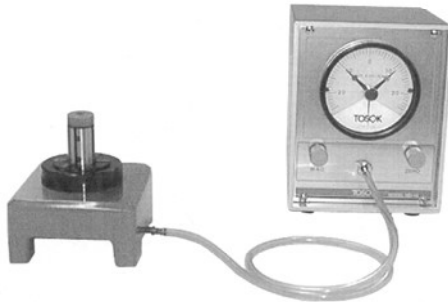

- 5-5 Bend the vinyl hose leading to the measuring unit completely by finger (or shut the nozzle tightly with your finger tips) and check that the pointer of the indicator turns clockwise and exceeds the full scale.

6. Adjustment

6-1 Operation of adjust knobs

Two adjust knobs (MAG and ZERO) are provided on the lower front of the instrument. The MAG knob is used for adjusting the magnification and the ZERO knob is used for adjusting the zero position.

Turning the magnification adjust knob clockwise will increase the magnification and will move the pointer leftward. Turning it counterclockwise will decrease the magnification and move the pointer rightward.

Turning the zero adjust knob clockwise will move the pointer rightward and turning it counterclockwise will move the pointer leftward. The indicating position can be corrected by these adjustments.

6-2 Example of adjustment for inner diameter measurement

Instrument to be used: MD-14L (25-0-25)

Measuring dimension: $\phi 30 \pm 0.010$

Master gage size: Max. master gage; $D + \alpha = \phi 30.010$

Min. master gage; $D = \phi 29.990$

Gaging head: $d = \phi 29.975$

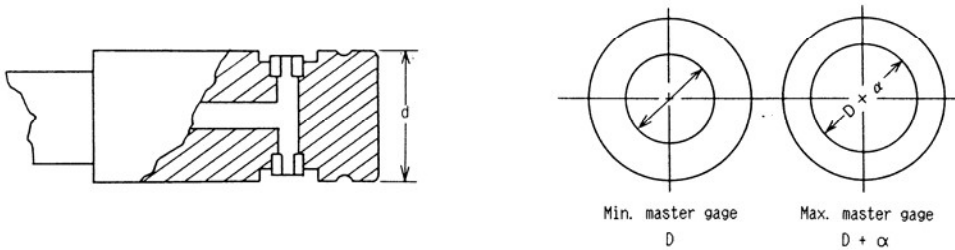

- 1) Thoroughly wipe the gaging head and master gages.
- 2) Insert the gaging head into the min. master gage.
- 3) Turn the zero adjust knob until the pointer indicates "10" on the right scale.
- 4) Insert the gaging head into the max. master gage.
- 5) When the pointer does not reach "10" on the left scale (Fig. 1), the magnification is too low. In this case, once turn the magnification adjust knob clockwise until the pointer exceeds "10" and reaches "25" on the left scale and then, turn the zero adjust knob clockwise so as to return the pointer to "10" on the left scale. (The Fig. 2 shows how to adjust when the magnification is too high.)

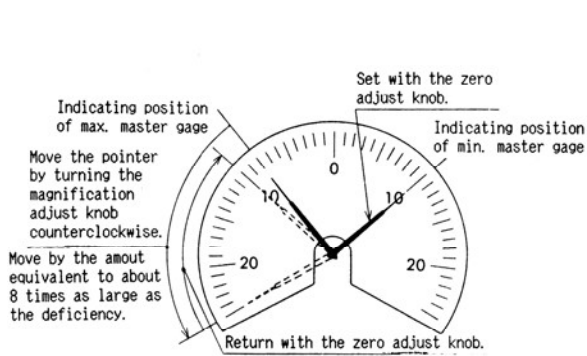

Fig.1 When magnification is insufficient (Insufficient by 2μ in this example)

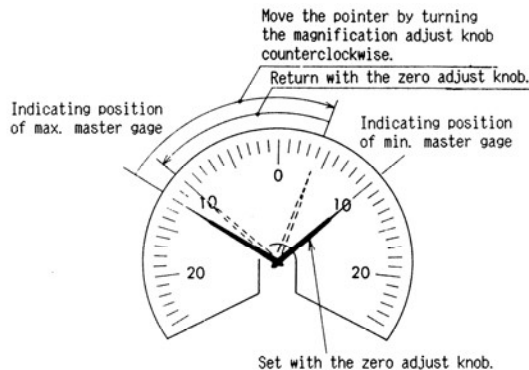

Fig.2 When magnification is excessive (Excessive by 2μ in this example)

- 6) Insert the gaging head into the min. master gage.
- 7) When the pointer does not reach "10" on the right scale, turn the zero adjust knob until the pointer reaches "10" on the right scale.
- 8) Insert the gaging head into the max. master gage.
- 9) When the pointer does not reach "10" on the left scale, perform Step 5) once again. As the deficiency is reduced by repeatedly making the adjustment of Step 5), gradually reduce the degree to let the pointer exceed "10" on the right scale using the magnification adjust knob. (When the magnification is to be increased or decreased by 1μ , it is necessary to move the pointer by about 8μ using the magnification adjust knob. Assume the amount to be adjusted on the scale to be about 8 times as large as the actual magnification to be corrected.)
- 10) Repeatedly perform steps 1) to 5) until each pointer is accurately set to the indicating position of each master gage.
- 11) After completion of adjustment, set the limit indicators to the indicating position of the max. master gage and min. master gage, respectively. (Fig. 3)

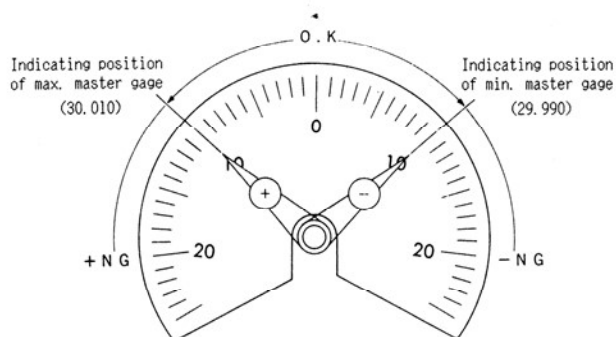

Fig. 3 Limit indicators

6-3 Example of adjustment for outer diameter measurement

Instrument to be used: MD-14L (25-0-25)

Measuring dimension: $\phi 30 \pm 0.010$

Master gage size: Max. master gage; $d = \phi 30.010$

Min. master gage; $d - \beta = \phi 29.990$

Gaging head: $D = \phi 30.025$

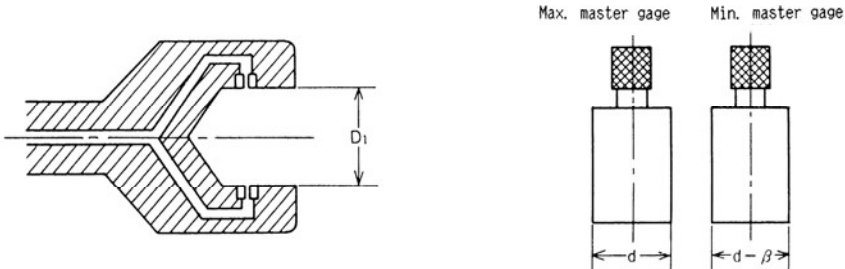

In case of adjustment for outer diameter measurement, the indicating position of the max. master gage and that of the min. master gage are opposite to those for the inner diameter measurement, respectively. Namely, set the indicating position of the max. master gage at "10" on the right scale and that of the min. master gage at "10" on the left scale.

When the magnification is too low or too high, the steps of procedure of adjustment are the same as those for the inner diameter measurement. In this case, however, note that the indicating position of the max. master gage and that of the min. master gage are opposite to those for the inner diameter measurement, respectively.

Use the zero adjust knob to set the pointer to the indicating position of the max. master gage and use the magnification adjust knob and zero adjust knob to set the pointer to the indicating position of the min. master gage.

Refer to Fig. 1 and Fig. 2.

7. Maintenance and Operating Precautions

- 1) Be sure to drain the filter unit every morning or more frequently according to the air supply condition in the factory.
- 2) According as the auxiliary filter is used for a long period of time, the inner felt discolors. In this case, replace the felt with a new one as soon as possible.
- 3) When cleaning the air escapement of the gaging head, first wash it with low-viscosity oil and then, wipe with soft cloth.
Never clean the jet surface with a metallic material.
- 4) When the gaging head or master gage is not used for long, apply rust preventive oil.
- 5) After replacing the parts or resetting the piping, check that no air leaks in it, with soapy water.
- 6) Cleaning the main unit
Close the filter cock to stop the air supply. Then, remove the vinyl hose of the supply joint, the magnification adjust knob and the zero adjust knob on the front panel.
Pour a small amount of alcohol into the supply joint (never use thinner or such a solvent that will melt the diaphragm in the filter), and connect the supply hose again. In this state, let flow air and push the cleaning button on the rear of the regulator several times.
Clean the two adjust knobs by blowing air or with alcohol. Then, remount them to the panel.
Clean the Air Gage at least once a month in the above-mentioned manner.

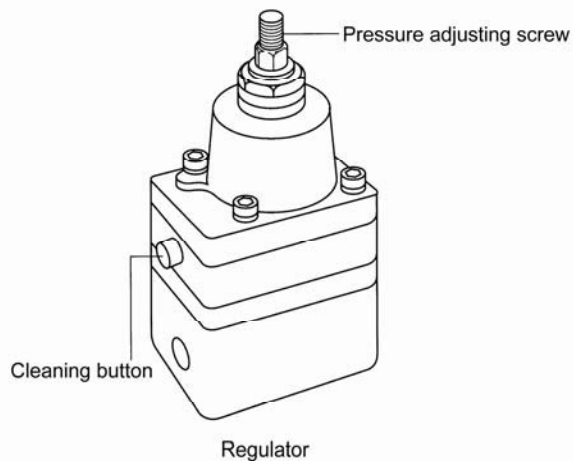

8. Troubleshooting

If something wrong with the Air Gage while operation or adjustment, check and readjust it, referring to the table below.

| Trouble | Cause or defective part | Countermeasures |
|---|--|---|
| 1. Repeatability of indication is not stabilized. | <p>A. Jet of gaging head is stained.</p> <p>B. Holder of gaging head is not firmly fixed.</p> <p>C. Air leak in piping or joints.</p> <p>D. Inside of main unit is stained with oil or dirt.</p> | <p>A. Clean thoroughly.</p> <p>B. Adjust nozzle clearance properly and retighten completely to keep proper clearance.</p> <p>C. Check leak part with soapy water and retighten.</p> <p>D. Clean thoroughly.</p> |
| 2. Pointer fluctuates. | <p>A. Air leak in piping or joints.</p> <p>B. Oil or other matters are clogging in main unit.</p> <p>C. Main unit suffers excessive vibration from outside.</p> | <p>A. Check leak part and retighten.</p> <p>B. Clean.</p> <p>C. Check cause of vibration. If necessary, use vibration-proof material.</p> |
| 3. Zero adjust knob fails to work. | <p>A. Supply pressure is low.</p> <p>B. Leakage in piping or joints.</p> <p>C. Nozzle clearance is too close.</p> <p>D. Nozzle clearance is too open.</p> <p>E. Indicator is defective.</p> | <p>A. Adjust to keep $4\text{kg}/\text{cm}^2$ or more.</p> <p>B. Firmly retighten leak part.</p> <p>C.</p> <p>D. Readjust to proper nozzle clearance.</p> <p>E. Replace indicator.</p> |
| 4. Actual size does not agree with indicated value. | <p>A. Restriction regulator is clogged.</p> <p>B. Restriction is stained.</p> | <p>A. Push cleaning wire button several times.</p> <p>B. Clean.</p> |

9. Special applications

o Measurement of taper

The error of a taper can be measured by blowing air to two or more points on the inner surface of the taper so as to indicate the displacement at each point.

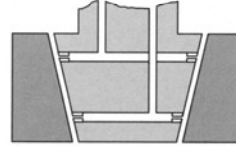

o Measurement of distance between centers

The distance between centers can be measured by means of a special measuring instrument incorporating two gaging heads, each of which has two nozzles that blows air in opposite directions respectively.

There is no possibility that measured values are affected by diametral deviation.

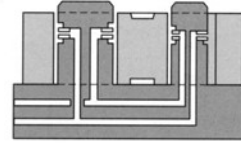

o Measurement of straightness of hole

The straightness of a hole is inspected with only one gage as shown in the Fig. on the right. The error of straightness can be known by a change in readings when the gage is rotated.

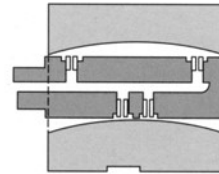

Regulator

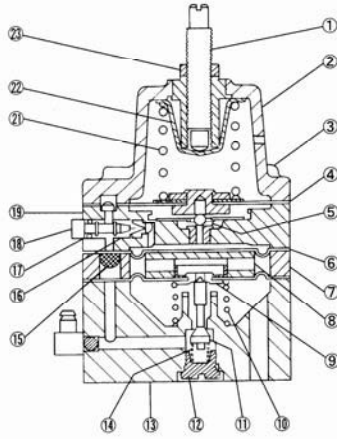

| No. | Part name | Q'ty | No. | Part name | Q'ty |
|-----|---------------------------|------|-----|-----------------------------------|------|
| 1 | Adjust screw | 1 | 12 | Seal screw | 1 |
| 2 | Top housing | 1 | 13 | Pilot base | 1 |
| 3a | Bolt SSH-M4 x 0.7 x 35 | 2 | 14 | Plunger spring | 1 |
| 3b | Spring washer WAP-4 | 2 | 15 | Spring insert | 1 |
| 4 | Top diaphragm ass'y | 1 | 16 | Spring (10320-10) | 1 |
| 5 | Leaf spring ass'y | 1 | 17 | O-ring SM720 Nitrile rubber | 1 |
| 6 | Diaphragm | 1 | 18 | Cleaning wire | 1 |
| 7 | Exhaust ring | 1 | 19 | Pilot ring | 1 |
| 8 | Spacer | 1 | 20 | Plunger stopper | 1 |
| 9 | Exhaust diaphragm ass'y | 1 | 21 | Spring (8678-7) | 1 |
| 10 | Spring (8678-6) | 1 | 22 | Spring sheet | 1 |
| 11 | Pilot plunger | 1 | 23 | Locknut | 1 |

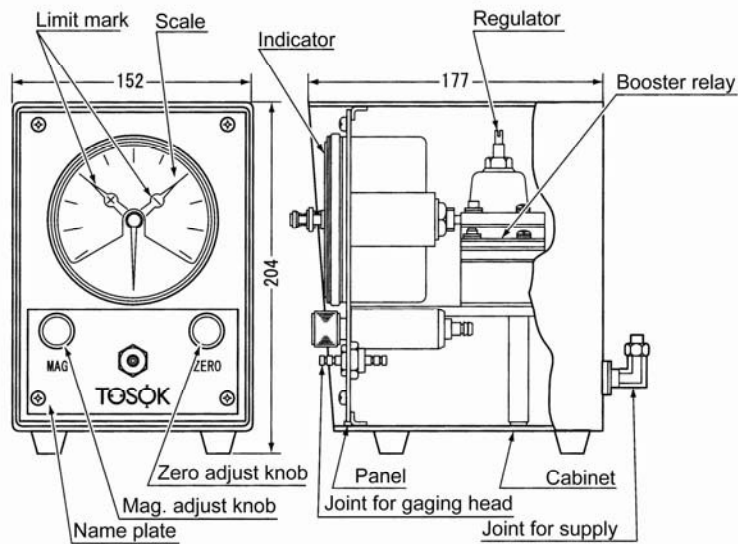

Filter Unit (Model FUA-503)

External drawing

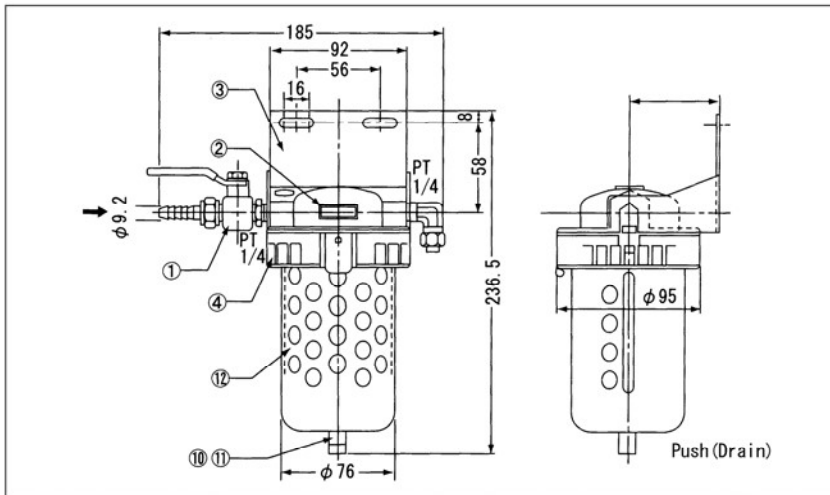

- | | |
|--------------|------------------|
| ① Cock | ⑩ Flexible drain |
| ② Name plate | ⑪ Ball protect |
| ③ Bracket | |
| ④ Air filter | |

Component parts

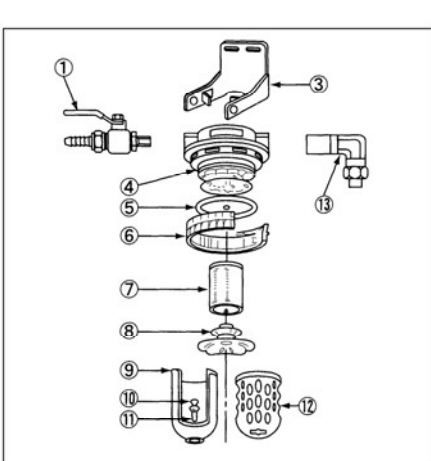

- | |
|----------------|
| ① Cock (SV-2A) |
| ③ Bracket |
| ④ Main unit |
| ⑤ O-ring |
| ⑥ Clamp ring |
| ⑦ Y element |
| ⑧ Baffle |
| ⑨ Ball |
| ⑩ Valve |
| ⑪ Drain sheet |
| ⑫ Ball protect |
| ⑬ Joint |

Specifications

| | |
|---|--|
| Max. operating pressure | 9.5 kg/cm ² |
| Resisting pressure | 15 kg/cm ² |
| Operating temperature range | 5 ~ 65°C |
| Efficiency of filtration | 0.3 μm |
| Removing of tar or carbon | 99 % |
| Max. flow rate | 0.5 Nm ³ /min (Input : 7 kg/cm ² , Pressure drop:0.1 kg/cm ²) |
| Nipple diam. | PT 1/4 |
| Weight | 1.6 kg |
| <p>o Flexible drain The filter unit can be manually drained by pushing the adaptor sideways.</p> <p>o Normally, pressure drop is less than 0.1 kg/cm² at an early stage. When it reaches 0.7 kg/cm², the filter element is used up. So, it is necessary to replace the filter element with a new one.</p> | |

Magnification and Zero Adjust Knob

1. If this knob is left as it is for long, the vaseline applied dries up, so that the O-ring may not be turned to immobilize the knob.
To avoid such trouble, apply vaseline and replace the O-ring periodically. Also, if the bleed hole is not used for long, oil and water in the air accumulate in the bleed hole, thereby giving resistance to it.
Clean them with a air gun etc.

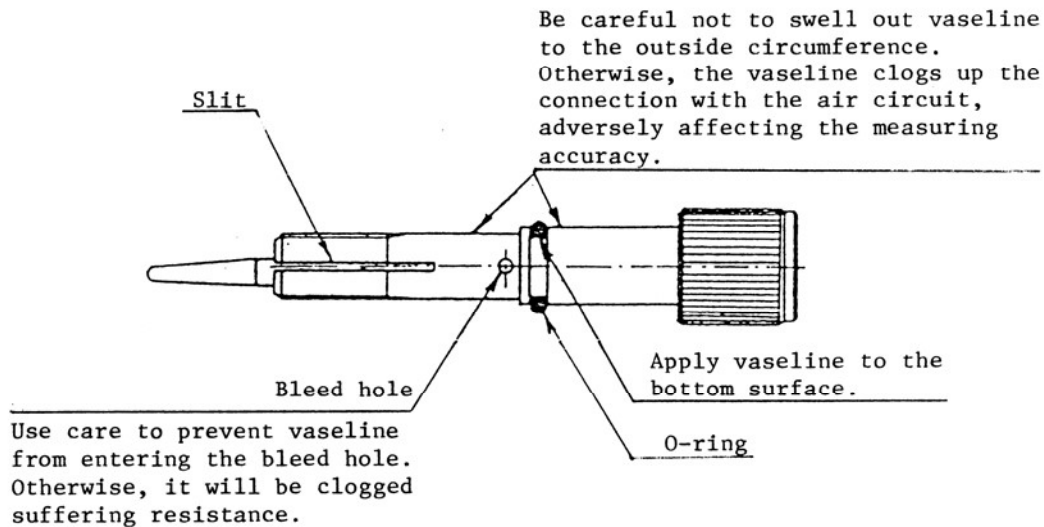

2. When the adjust knob is loose, expand the slit with a minus (-) screw driver while using care not to damage the screw.
When the adjust knob is tight, protect the screw with a cloth and narrow the slit with pliers etc. In this case, adjust the knob so that it becomes slightly tight. If the knob is loosely adjusted, it will move backward and forward by the backlash of the screw when the air source is opened or closed. Consequently, the indicating position set at the beginning will slightly change.
Carefully avoid damage to the screw in case of adjustment.
Even a slight damage to the screw will lead to its bad fitting.

Indicator

If a pressure of 3.5 kg/cm^2 or more is applied to the indicator, the Bourdon tube will be overloaded making the indicator unusable.

Check the Bourdon tube for leakage by burst as follows :

1. Loosen the front panel set screws (4 pcs.) and draw out the front panel.
2. Open the air source to flow air.
3. Put a master gage into the gaging head and set the indicator pointer at a desired position. (Follow the same procedure as above when using a block gage for the direct type stand ADS-200.)
4. Pinch the vinyl hose connecting from the booster (MD-14L, 24L) or amplifier relay (MD-14M, 24M) to the indicator with pliers to stop the flow of air to the indicator.
5. See the indicator. When the pointer set at a desired position does not shift, the Bourdon tube is normal. If the pointer lowers, the Bourdon tube leaks by burst. In this case, replace the indicator immediately.

Regulator

If it is used for long with its inside contained oil or water, the diaphragm will deteriorate and the throttle will be choked. Consequently, air cannot be supplied at a stable pressure, adversely affecting the measuring accuracy.

Usually, air source contains water or oil to some degree. So, check the felt of the auxiliary filter for dirt. If it is excessively dirt, the regulator contains oil. In this case, disassemble the regulator and replace the diaphragm with new one and clean the other component parts.

When assembling the regulator, fully loosen the adjust screw.

Refer to the detailed internal drawing of the regulator shown in Page 13.

Adjust pressure after assembly while using care to the following points.

1. Adjust pressure in the regulator alone before mounting the panel and piping.
2. When supplying air to the indicator, be sure to check that air pressure to the regulator is set at 3 kg/cm^2 .

As described in the former paragraph "Indicator", if the Bourdon tube receives a pressure of 3.5 kg/cm^2 , a measuring error will occur.

If the pressure of air source in the factory is not adjusted due to imperfect assembly of the regulator and is directly applied to the indicator, it is overloaded. To avoid this, be sure to check that air pressure is properly adjusted, before mounting the panel and piping.

Adjust pressure in the following order.

1. The pilot base has three joints, two joints of which are similar in shape. The joint of different shape is used for supply. (Model : LIN5-16-PT1/8) Insert the supply joint into the hose (Model : SYNFLEX "U" TUBING 5/16 (yellow)) coming from the auxiliary filter and tighten the nut. The joints of the same shape are used for output. Connect one of them to the pressure gage. Use a large pressure gage with a dial of 0 to 6 kg/cm² for assuring accurate reading. Blind the remaining joint to prevent air from getting out.
2. Turn ON air supply.
3. Set air pressure at 3 kg/cm² with the adjust screw of the regulator while seeing the pressure gage.
4. Open and shut the blank plug to check that air pressure comes to the required setting accurately and quickly.
5. After completion of pressure setting, lock the nut.
6. Apply soapy water to the outside circumference with a pint brush and check for air leakage.
7. Put your finger on the bleed hole to check whether or not air comes out from this hole excessively.
8. Remove all hoses inserted into the joint.
9. Mount the regulator to the panel.
10. Carry out piping as specified. (Connect the three joints with hoses respectively.)

Booster relay (used in MD-14L, 24L) and amplifier relay (used in MD-14M, 24M)

Do not disassemble the booster relay and amplifier relay, as they have been thoroughly adjusted in our factory.

If measuring accuracy becomes worse due to defect in the booster relay or amplifier relay, sent it to our company.

It will be inspected and repaired or replaced (cost charged) in our company.

Air Circuit

The air circuit is entirely composed of air hoses.

If the air hoses are left as it is for long, they lose flexibility causing air leakage in the joint. Check for flexibility by pressing them with fingers.

If the hose feels hard replace with a new one.

Limit Mark

The limit mark is made of metal but the transparent lid is made of acrylic resins. So, do not use a volatile solvent such as thinner, fluoric solvent, trichloroethane, etc. Otherwise, the lid becomes dull or cracks.

Wipe off dirt with soapy water.

Filter and Auxiliary Filter

Always check the felt of the auxiliary filter for dirt.

If it is a extremely dirt, it cannot perform its filtering function, causing to lower the pressure. In such a case, replace with a new one as soon as possible.

If it has no filtering function, dirty air enters the regulator, booster relay, amplifier relay, etc., thus deteriorating the diaphragm and the measuring accuracy.

When cleaning the outer cylinder of the auxiliary filter in case of overhaul, do not use a volatile solvent such as thinner, fluoric solvent, trichloroethane, etc. Otherwise, the filter becomes dull or cracks, and it may burst when air is supplied to it.

Be sure to drain before and after operation.

This filter element and felt can be easily replaced. For further details, refer to the internal detailed drawings of the filter and auxiliary filter shown in Page 14.

When assembling the filter, firmly tighten it while using care to prevent looseness in it. If any of looseness occurs in the filter, air directly enters the regulator, booster relay, amplifier relay, etc. without passing through the element.

Joint and Hose

The inner diameter of the joint that connects the auxiliary filter with the main unit has become larger than that of the old one, as the result of taking account of air supply pressure.

The new joint has a yellow hose (SYNFLEX "U" TUBING 5/16), and the old joint has a milky white hose.

The new joint is sticked with a certificate so that it can be easily distinguished from the old one.

The hose color has become yellow since April 1979.

Larger than usual

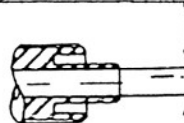

Others

When this instrument is used in a production line, the vinyl hose, packing, etc. will be deteriorated due to dirty air in the factory and adhesion of oil in case of measurement, thereby causing air leakage.

So, replace these parts periodically.

Stock of Parts

Some parts may not be immediately delivered according to circumstances.

It is recommended that the user stocks the following parts in advance :

Indicator, Booster relay, Amplifier relay, Diaphragm, Filter element,
Felt and Vinyl hose

Please specify the parts number of regulator and filter shown in
Pages 13 and 14.

SEALS USA, Inc.

Instruments Division

Tel: (630)924-7138

Email: support@seals-usa.com