

Operation Manual



Warning

Do not operate or store instrument in the following locations:

Explosive areas, near water, oil, dust or chemicals; areas where the temperatures can exceed 104°F (40° C)

Take precaution to not drop the force gauge. Damage to the sensor may occur.

Do not modify, disassemble or attempt to repair the unit. Send to the factory for proper repair.

If upon delivery damage to the unit is detected, do not operate the unit. Notify the shipping carrier immediately to obtain damage claim instructions.

Only measure forces that are in line with the measuring shaft. Do not attempt to take any measurements (tension or compression) at any angle. Failure to keep measurements in line will damage the instrument.



The Series FGE-XY Digital Force Gauges combine a rugged, ergonomic and compact design with exceptional accuracy to provide a solid force testing instrument. These instruments are utilized in a variety of applications such as, incoming quality inspection, finished goods testing, R&D or almost any portable or force stand testing requirement.

Simple one button adjustment alters units, while pressing the peak button quickly produces the highest recorded value during the test. The 180° reversible display combined with the adjustable force direction and dual labeled keypad enable the FGE-XY to excel in both compression and tension applications in any direction. Models are available from 0.5 lbs to 200 lbs ranges providing a large offering for various testing requirements.

Typical applications include wallboard, wire pull, wire crimps, trigger pull, brake pedal, aerospace ceramic, springs, food ripeness, corrugated paper strength, blister pack, medical component, muscle strength, ergonomic testing, adhesives, syringe plunger, needle sharpness and many more.

Specifications

Capacity: See table, page 3.

Resolution: See table, page 3.

Accuracy: $\pm 0.2\%$ F.S. @ 73°F (23°C)

Display: 4-Digit LCD, 0.5" (12 mm) high, Units 0.29" (7 mm). Reversible. Minus sign for tension.

Display Update: 0.05, 0.1, 0.2, 0.3, 0.5, 1 sec

Sampling Rate: 1000 Hz

Overload Capacity: 200% of F.S. (200 lb.: 150% F.S.)

Power: Rechargeable Ni-MH battery or universal AC adapter/charger (100 - 240 VAC, 50/60 Hz)

Auto Power Shut-Off: Yes (not active if adapter/charge is in use)

Battery Charge: 12 hours (when fully charged)

Recharge Time: Approximately 18 hours (when fully discharged)

Temperature Limits:

Dimensions: 5.8 x 3 x 1.5" (147 x 75 x 38 mm)

Product Weight: Approx. 1 lb (450 g); FGE-200XY Approx. 1.1 lb (500 g)

Package Weight: Approx. 2.25 lb (1.02 kg) for 0.5 lb and 1 lb ranges; 2.4 lb (1.09 kg) for 2 to 100 lb ranges; 2.75 lb (1.25 kg) for 200 lb range.

Approvals: CE, RoHS

Warranty: 1 Year

Included Accessories: AC adapter/charger, carrying case, hook, chisel, flat head, notched head, hanger, cone head, metric to inch thread adapter, extension rod

PRODUCT DIAGRAM

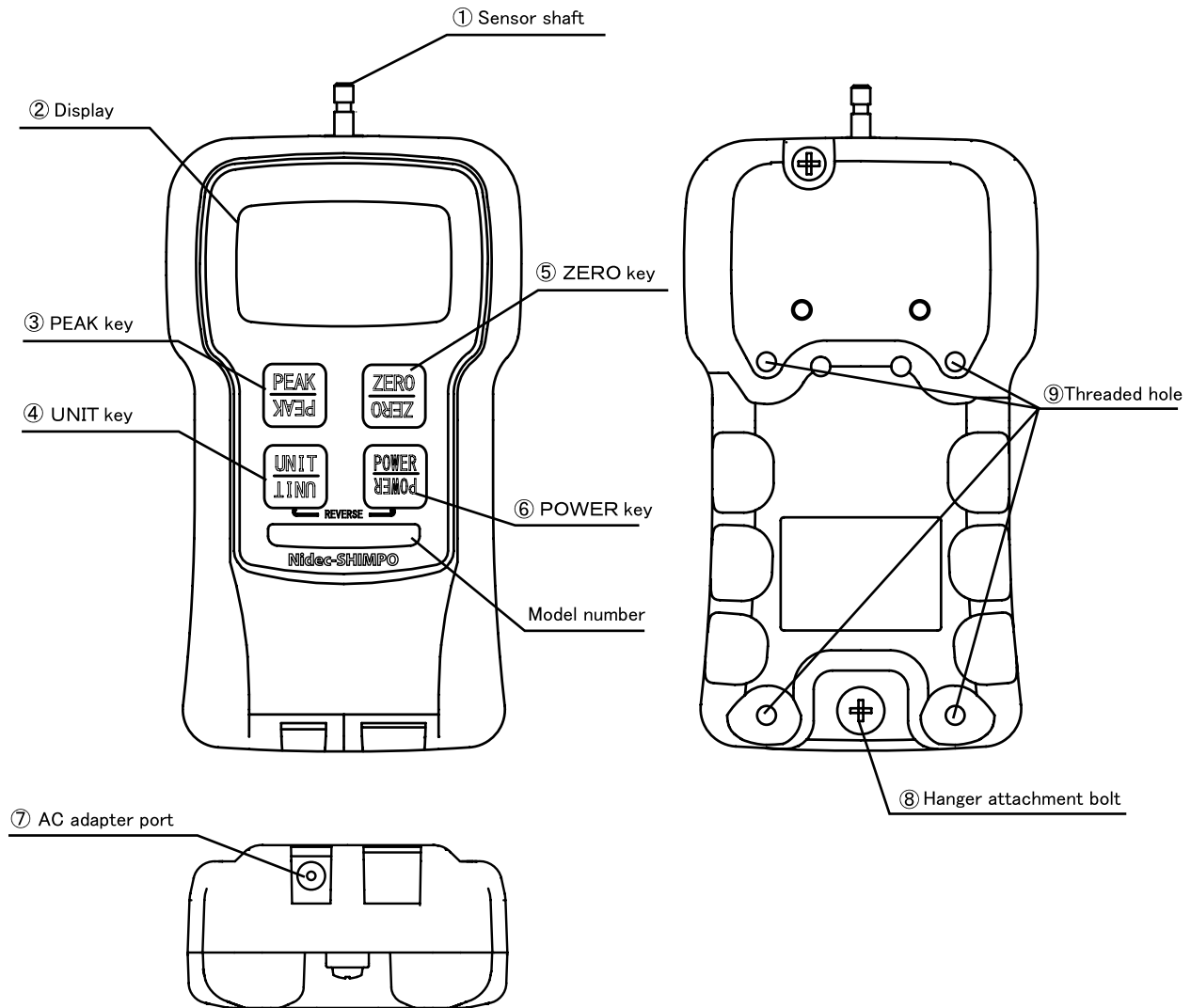

①	Sensor shaft	Force bolt (Push/Pull Force)
②	Display	Display the load and the unit.
③	PEAK key	<ul style="list-style-type: none"> • Switch standard measuring mode, + peak hold mode, or - peak hold mode. • Tracking ON/OFF.
④	UNIT key	<ul style="list-style-type: none"> • Switch the unit (N ⇒ kg ⇒ lb(oz) ⇒ N) • It is used to reverse the display. • Tracking ON/OFF.
⑤	ZERO key	<ul style="list-style-type: none"> • Tare at standard measuring mode (not display a peak value). • It is used for function setting. • Press the ZERO key under the peak hold mode (display the peak value), to clear the peak value. In this case, tare does not perform. If you need tare, press the peak key to change into standard measuring mode, then press the Zero key.
⑥	POWER key	<ul style="list-style-type: none"> • Press the POWER and release to turn ON/OFF. • It is used to reverse the display. • Tracking ON/OFF.
⑦	AC adapter port	Supply the electricity through the AC adapter.
⑧	Hanger attachment bolt	Attach the hanger with this bolt.
⑨	Threaded hole	Use this threaded hole in order to attach the FGE with a stand.

FGE-XY Model	FGE-0.5XY	FGE-1XY	FGE-2XY	FGE-5XY	FGE-10XY	FGE-20XY	FGE-50XY	FGE-100XY	FGE-200XY
Capacity	8 oz 0.5 lb 200.0 g 2.000 N	16 oz 1 lb 500.0 g 5.000 N	32 oz 2 lb 1,000 g 10.00 N	5 lb 2.000 Kg 20.00 N	10 lb 5.000 Kg 50.00 N	20 lb 10.00 Kg 100.0 N	50 lb 20.00 Kg 200.0 N	100 lb 50.00 Kg 500.0 N	200 lb 100 Kg 1000N
Resolution	0.01 oz 0.001 lb 0.1 g 0.001 N	0.01 oz 0.001 lb 0.1 g 0.001 N	0.01 oz 0.001 lb 1 g 0.01 N	0.001 lb 0.001 Kg 0.01 N	0.01 lb 0.001 Kg 0.01 N	0.01 lb 0.01 Kg 0.1 N	0.01 lb 0.01 Kg 0.1 N	0.1 lb 0.01 Kg 0.1 N	0.1 lb 0.1 Kg 1N

OPERATION

To Begin:

1. Charge the batteries for approximately 17 hours before using the gauge. The batteries come discharged from the factory.
2. Hand-tighten appropriate attachment to units measuring shaft. Do not use wrench or any other device or tool to tighten the attachments to the shaft.
3. Press Power and release. The unit will display model name in the upper display and the capacity in the main display.

Change Display Units

To change the display units, simply press UNIT and the units will change with each subsequent press of the button.

Reverse the Display

If the gauge is used with the included hanger or mounted on a test stand, the display must be reversed.

1. Press POWER and hold. The display will go blank.
2. Press and hold UNIT.
3. Release POWER while still continuing to hold down UNIT. Display will still remain blank.

4. Press POWER once more and release it while still holding UNIT. At this point the display will appear and be reversed.

5. Release UNIT; the display stays now in the reverse mode.

To return to the normal mode, repeat steps 1-5.

Select Average or Peak

The unit can display the live Averaged reading or the Peak reading. Standard is Average.

If you want to measure the Peak force, follow this procedure:

1. Press PEAK; the word PEAK will appear in the upper left corner of the display. If you wish to have a minus sign on the Peak, press PEAK again.
2. The display will freeze and show only the peak force on any given test.
3. To reset the Peak reading, press ZERO to clear the current Peak reading and start over.

If you wish to go back to Average reading mode, press PEAK again. The PEAK icon will disappear from the display.

Taking a Measurement

After the appropriate attachment has been hand-tightened on the instrument, tare the unit by pressing ZERO.

Tension Measurement

To measure tensile forces, use the hook attachment provided. The display will show the force measured with a minus sign (-) to the left of the digits.

Note: To eliminate the minus (-) sign during tensile operation, this may be changed. Review the “Function Setting” section.

Compression Measurement

To measure compression forces, use the flat head attachment provided. The display will not show any sign for compression.

Note: To display a minus sign (-) for compression forces, consult the “Function Settings” section for making the change.

Low Battery

When the battery charge is low, LO BAT will appear indicating the batteries need to be charged. To completely charge fully depleted batteries requires approximately 17 hours of charging time with the unit off. The units possess a smart charging system that shuts off the charging circuit once the batteries are fully charged.

Note: The unit may operate with the charging adapter while the batteries are being charged. This will however lengthen charging time.

Auto Power Off

If the gauge is on and there is no activity for 10 minutes, the unit automatically powers off to conserve the batteries. At 9 minutes without activity, PWR appears to notify that there is 1 minute before auto power-off. If the charging adapter is powering the gauge, the auto off function is inactive.

Note: To modify the auto power off function, consult the “Function Setting” section.

Tracking Function

The tracking function accounts and compensates for temperature drift. It is advised to keep this function running for optimal performance. However, when measuring very minute forces (a few ounces or grams) at a very slow rate, it may be advisable to disable this function.

To turn the tracking function off, follow these steps:

1. Turn POWER off
2. Press PEAK and UNIT switches simultaneously and hold. Then press and release POWER. If the tracking function was on, the display will show TRK OFF momentarily to confirm successful disable.
3. Release PEAK and UNIT

The tracking function is now off. Repeat these steps to activate the tracking function. The gauge displays TRK SET when reactivated.

FUNCTION SETTING

To change the default parameters of the gauge, follow the procedure to access the settings:

1. Press and hold the ZERO button.
2. Press and release the POWER button
3. Each time the PEAK button is pressed, the unit will scroll through each of the functions.
4. Press the ZERO button to exit.

Power OFF;
Press and hold ZERO button. Press and release the POWER button.

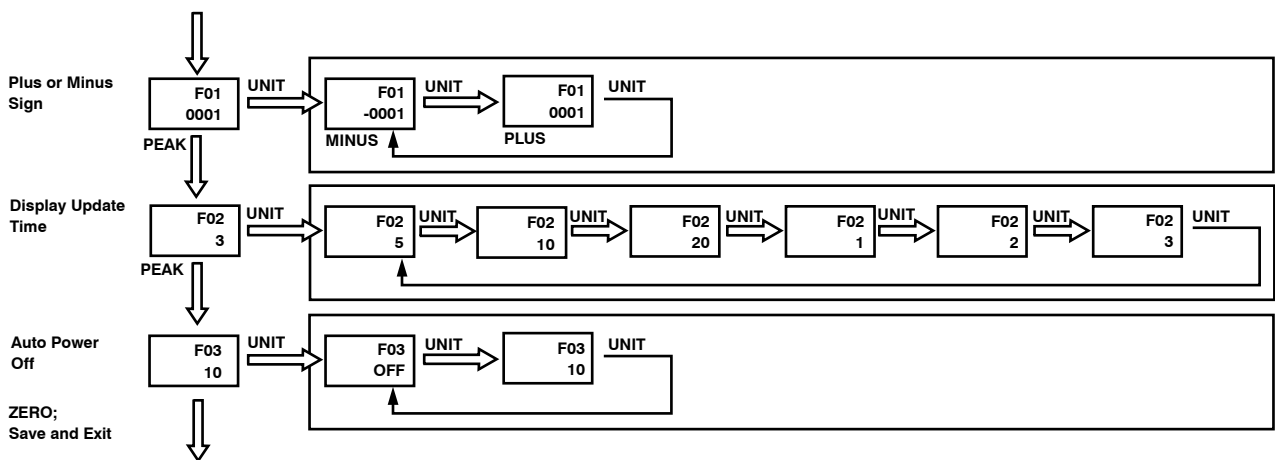

CALIBRATION REQUIREMENTS

1. Secure and mount force gauge to a calibration stand and mount the gauge upside down.
2. Obtain the appropriate full scale Metric range calibration weight of your unit.
3. Turn POWER OFF
4. Attach the fixture on the shaft of the force gauge. Thread and tighten onto shaft by hand only.
5. Press and hold the UNIT, PEAK and ZERO switches.
6. Press and release the POWER switch while still holding the other 3 switches. Continue holding the 3 switches until the display reads CAL, now release the three switches.

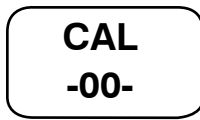

7. Press the UNIT switch. The display will blink SCN for 10 seconds then show ZER. The force gauge is now ready for zero point calibration.

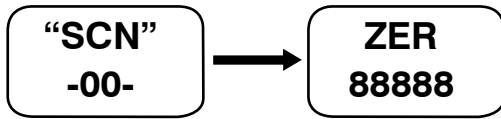

8. Press ZERO to zero calibrate. Wait approximately 18 seconds. The display will blink SCN then PEK. Do not press any other switches or move the sensing shaft during calibration.
9. Hang the calibration weight on the hook and stabilize. The process values will change. The gauge is now ready for full-scale calibration.
10. Press the PEAK switch to begin full scale calibration. Display blinks SCN. Do not press any keys or touch the unit or weight during calibration. After approximately 18 seconds, the display blinks END. After an additional 5 seconds, the display blinks OK if successful.

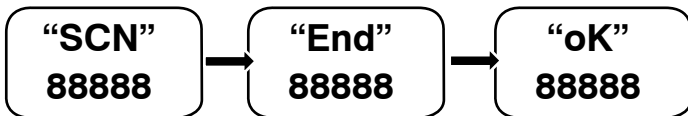

11. Press the UNIT button, the unit automatically powers off.

12. If calibration was unsuccessful, the display will show ERR. Remove the calibration weight, then press UNIT. Repeat the procedure to attempt for a correct calibration.

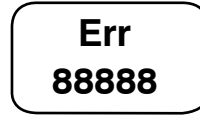

TROUBLESHOOTING

The following are general checkpoints. Please call Shimpo or your dealer for further assistance.

Force Gauges does not turn on: Check that power adapter is connected properly to unit and outlet.

Error codes are displayed: Turn unit off, then back on to reset. If error codes continue, see table below

Small Display	Condition	Action
OVR	The load exceeds 120% of its capacity	Remove excessive load.
ERR 3	EEPROM reading error	Turn off, then turn on again, if the display does not return to normal operation send unit in for repair.
ERR 4	EEPROM writing error	

DIMENSIONS

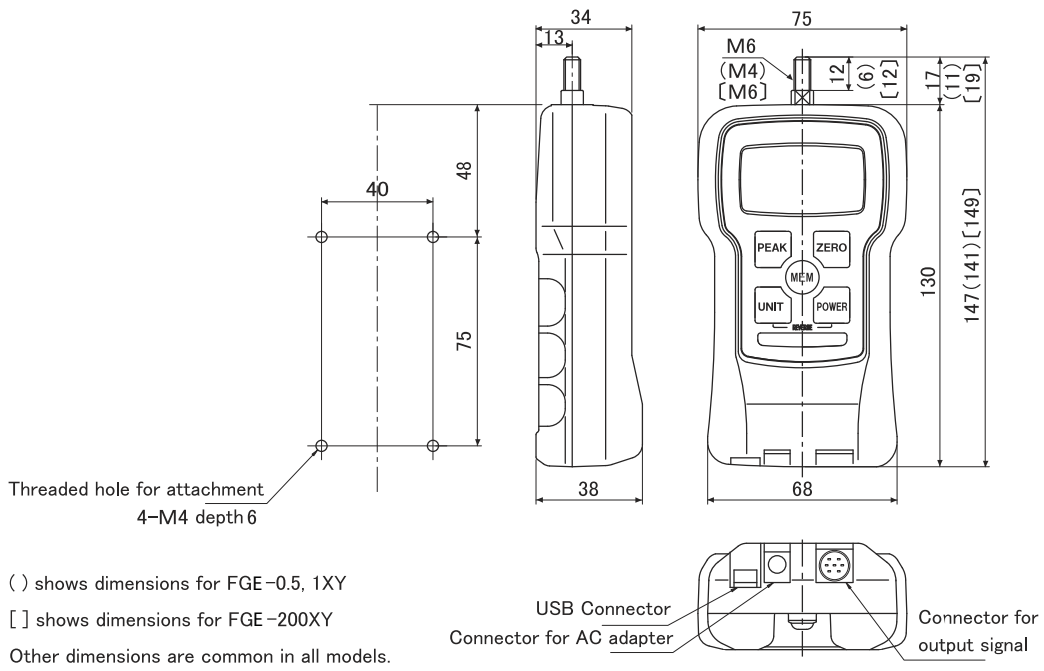

Force Gauge Adapter with M4 Connections: Models FGE-0.5XY & FGE-1XY

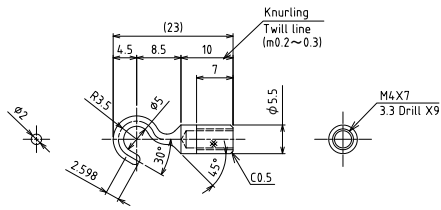

Hook

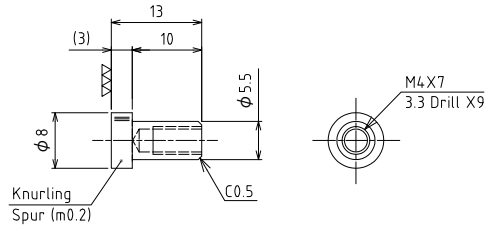

Flat Head

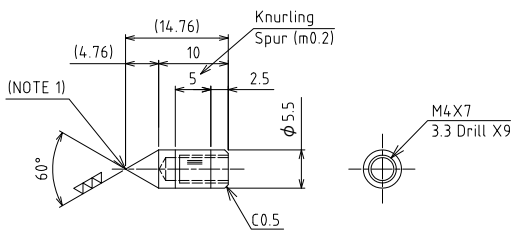

Cone Head

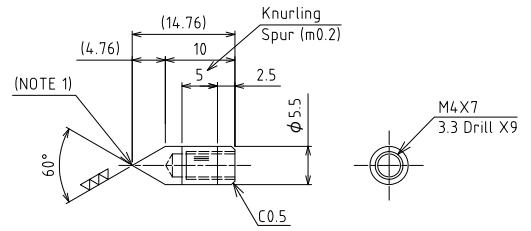

Chisel

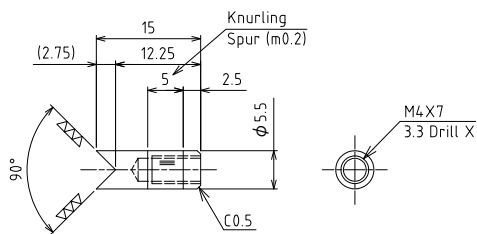

Notched Head

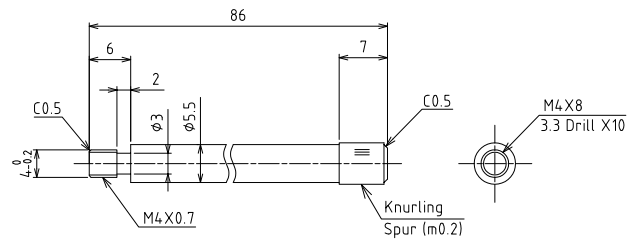

Extension Rod

Force Gauge Adapter with M6 Connections: Models FGE-2XY through FGE-200XY Note: Hook to 100 lb only.

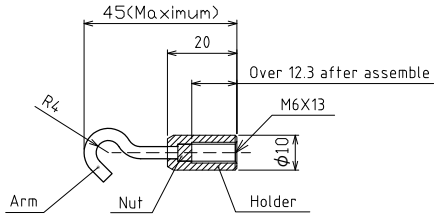

100 lb. Hook

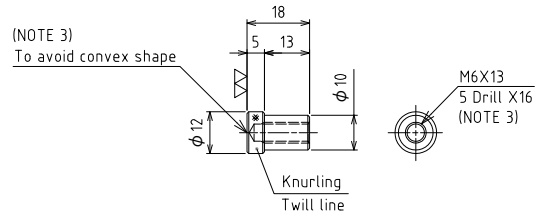

Flat Head

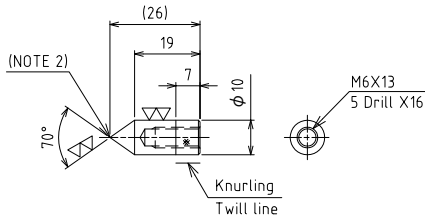

Cone Head

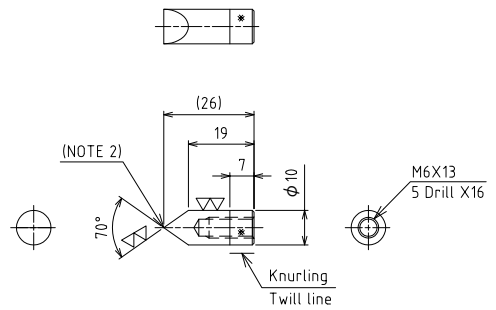

Chisel

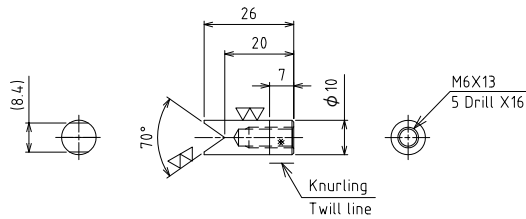

Notched Head

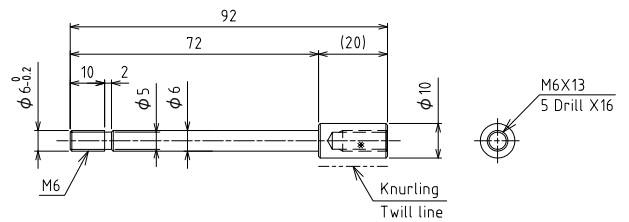

Extension Rod

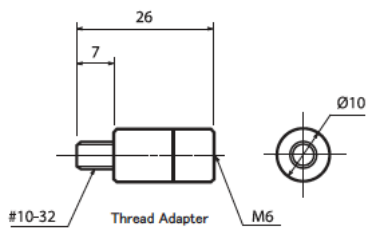

Thread Adapter

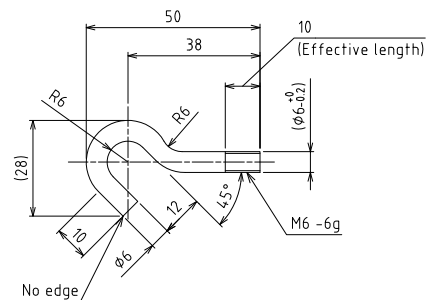

200 lb. Hook